

From Eye to Insight

Leica
MICROSYSTEMS



Premium Surgical Microscope

**STAY FOCUSED
FOR BEST RESULTS**

Leica M530 OH6
with FusionOptics



STAY FOCUSED WITH THE NEW LEICA M530 OH6

As a surgeon you have to remain focused on achieving the best clinical outcome for your patient. And on what matters in every single moment of the surgery. The Leica M530 OH6 has been designed to let you do just that by uniting the exclusive innovation FusionOptics with a truly ergonomic design.

FusionOptics technology combines resolution and depth of field. The result is amazing clarity of images. Along with one other advantage: less need to refocus. Plus, the truly ergonomic design allows you to position the microscope effortlessly and achieve a comfortable upright posture. Less muscle tension or even pain means steady concentration on your patient.

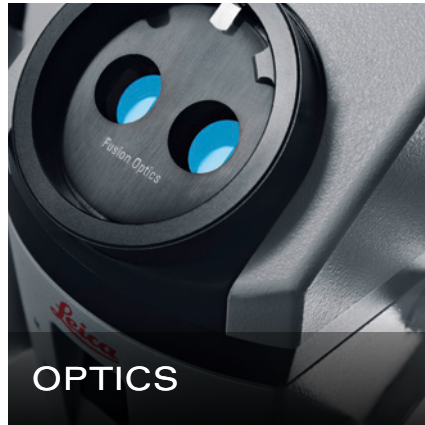

Stay focused with astounding optics

- > FusionOptics for high resolution with enhanced depth of field
- > Better visibility in deep cavities

See pages 4 to 5.



Stay focused with optimized ergonomics

- > More space to work
- > Full integration
- > Flexible positioning for everyone
- > Superior maneuverability

See pages 6 to 7.

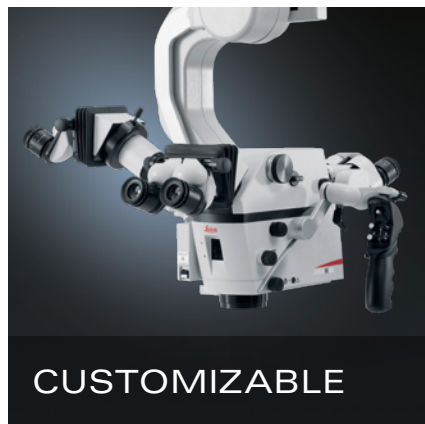

Stay focused with customized solutions

- > Individually configurable
- > Modular for changing needs
- > Imaging upgrades made easy

See pages 8 to 11.

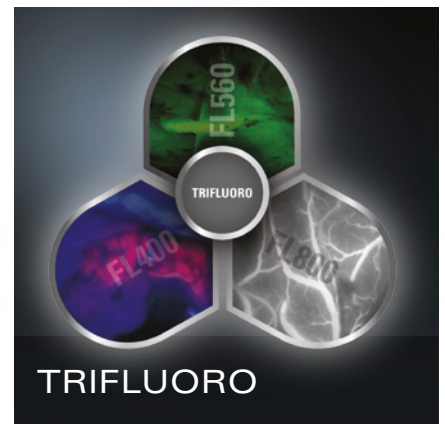

Stay focused with integrated fluorescence

- > Leica FL400 blue light fluorescence filter
- > Leica FL560 green light fluorescence filter
- > Leica FL800 for vascular fluorescence

See pages 10 to 11.

STAY FOCUSED WITH ASTOUNDING OPTICS

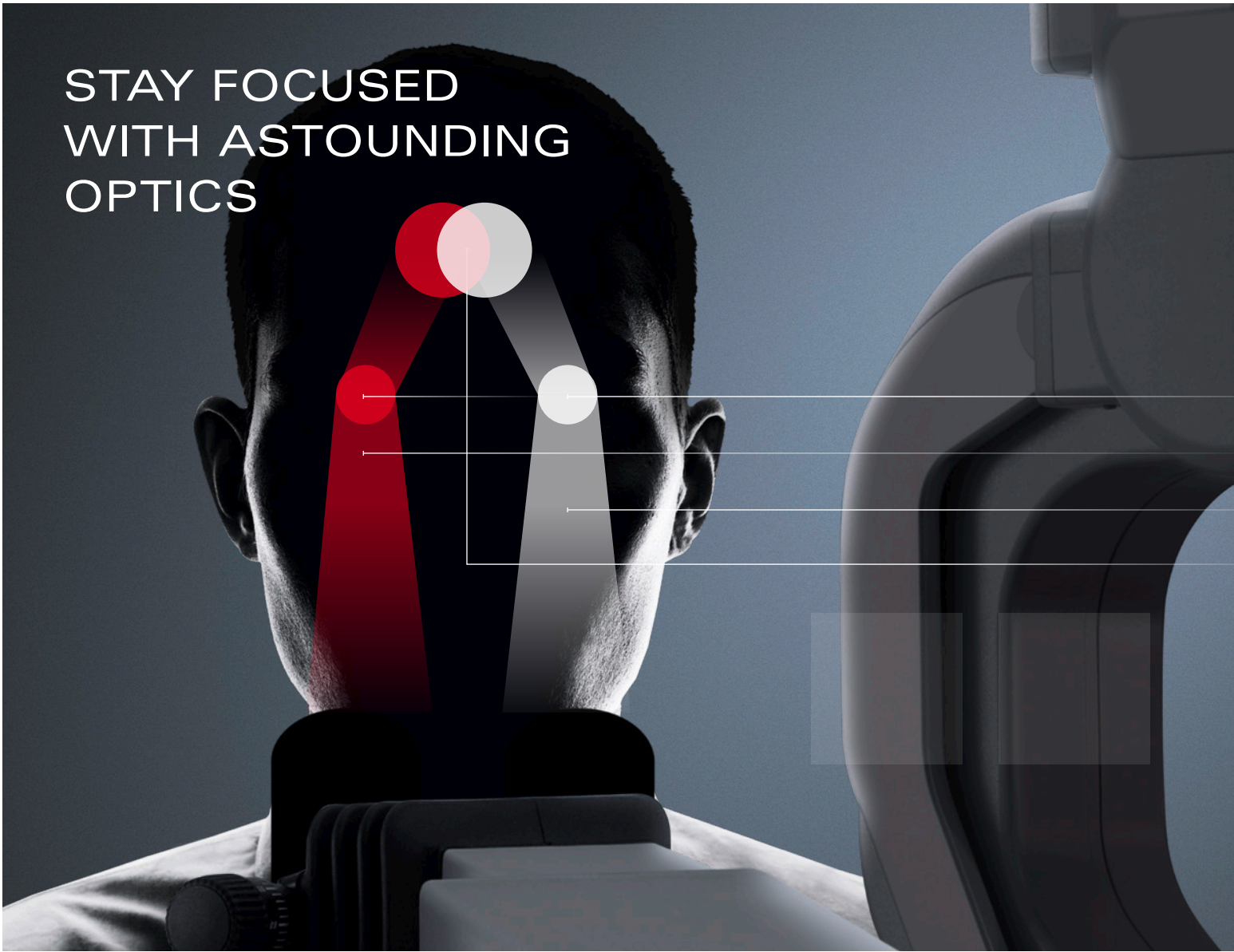

The Leica M530 OH6 takes image quality to a whole new level by combining FusionOptics with advanced illumination and apochromatic optics.

Visualize the finest details with FusionOptics

FusionOptics makes the impossible possible: large depth of field and high resolution in one image. This exclusive, groundbreaking technology from Leica Microsystems takes a new approach, utilizing the power of the human brain. First, it captures different information from each of the two beam paths. The left beam path delivers an image with the highest possible resolution and the right beam path provides an image with maximum depth of field. The brain then easily merges both images into a single, optimal spatial image. The astounding result: a significantly expanded area in full focus.

Less refocusing

FusionOptics technology offers a further unique advantage with the potential to streamline your workflow. A larger area in full focus means less time spent refocusing. FusionOptics helps you to stay focused, in every sense of the word.

FusionOptics Technology

1. Two separate beam paths
2. One beam path provides depth of field
3. The other provides high resolution
4. The brain merges the two images into a single, optimal spatial image

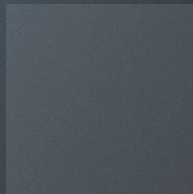
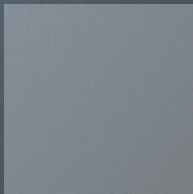
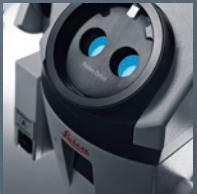

Deep insights

Small Angle Illumination (SAI) combined with bright 400-Watt xenon light provides a concentrated light beam that penetrates to the bottom of deep, narrow cavities. The result is better illumination with less shadow. SAI provides you with more details and an improved depth perception.

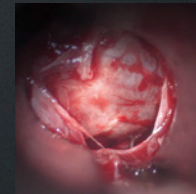

Without SAI (400 mm working distance)

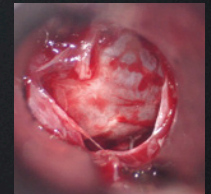

With SAI (400 mm working distance)



Magnification Multiplier



Rear FineFocus



Fast focusing

Customizable optics

Choose from the range of customizable optics and adapt the Leica M530 OH6 to your preferences:

- > Additional 40% magnification boost with the Magnification Multiplier (optional)
- > Independent fine focus for the rear assistant with a range of +/- 5 diopters
- > Fast focusing with two laser beams acting as a focusing reference to quickly provide a defined focus point for all three viewing positions (surgeon, assistant, camera)
- > A range of binoculars, all adjustable to different heights and positioning due to full 360°-rotation



Comfortable working posture and large free working space during a spine surgery

STAY FOCUSED WITH OPTIMIZED ERGONOMICS

Working in the most comfortable position possible is crucial during long surgeries.

That's why the Leica M530 OH6 is designed to fully adapt to you and your individual needs. Its comprehensive ergonomic concept was developed in close cooperation with leading surgeons, transferring their demands into intelligent ergonomic features. With less physical distraction, you can stay even more focused on the critical task at hand.

Easy handling for efficient workflow

- > Unobstructed access to surgical area with large 600 mm working distance. Enables use in spine procedures where previously only loupes could be used
- > Easy to maneuver and pass large instruments below the instrument
- > Compact optics carrier design means less distance from eyepiece to objective lens so arms can remain in a natural position and are not over-extended
- > Accommodates different operating positions and body frames with a range of binoculars, all with full 360°-rotation
- > Enhanced comfort and flexibility for the rear assistant with improved ergonomic design

compact optics carrier



more space to work (600 mm)

More space to work

With a compact base for space-restricted areas, superior overhead clearance and long reach, the Leica M530 OH6 offers you positioning flexibility and more space to work. Whatever the surgery: Position the microscope easily to best suit your needs and those of your team.

Long overhead reach

LEICA M530 OH6 - ERGONOMICS

superior overhead clearance

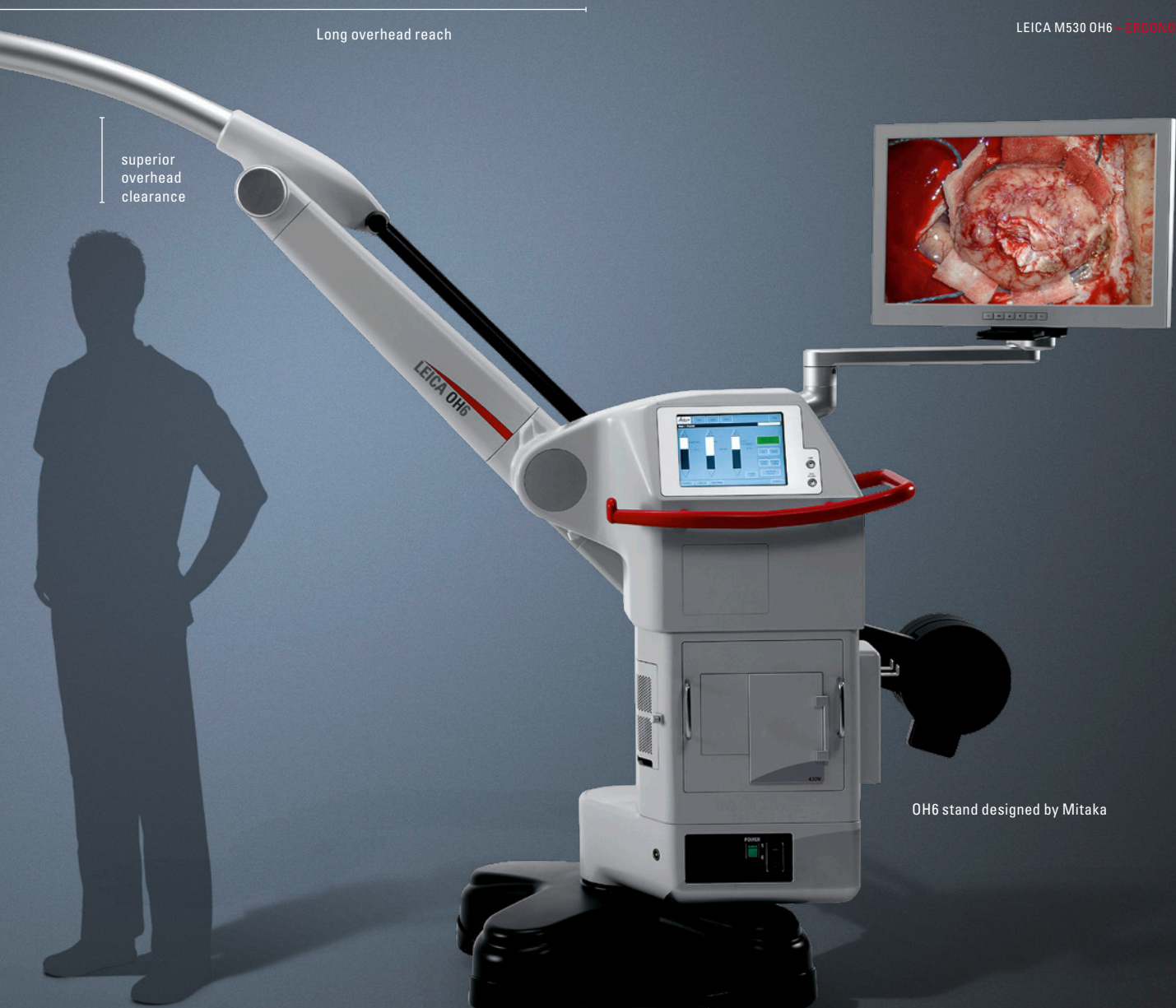

OH6 stand designed by Mitaka



Compact and fully integrated



Full range of movement and tilt of the optics carrier



Auto balance and manual balance

Comfortably ergonomic

The compact optics carrier provides more room to work and facilitates a more natural, ergonomic working position for the surgeon. All binoculars are adjustable to different surgeon heights and offer superior positioning due to full 360°-rotation.

Freely maneuverable

Smooth, effortless positioning reduces the potential strain of harsh movements and optimizes workflow efficiency. The extensive range of movement and tilt of the optics carrier along with the integrated design deliver unmatched flexibility. Fast stabilization keeps workflow interruptions to a minimum.

Perfectly balanced

Leica Microsystems' single button AutoBalance saves valuable time. With only two pushes of one button, the auto-balance system fully balances all six axes. To quickly and accurately re-balance the microscope intraoperatively, even through a sterile drape, simply push the AC/BC button, conveniently located above the optical head.

STAY FOCUSED WITH CUSTOMIZED SOLUTIONS

Equipped for the present, ready for the future. with maximum modularity for individual configurations.

Configure your Leica M530 OH6 to meet your needs perfectly. Its sleek, cable-free, fully integrated optics carrier was developed with a highly modular structure to specifically guarantee maximum configuration flexibility. Plus, keeping your imaging technology up-to-date just became so much easier. The OpenArchitecture and unique upgrade-ready design give you the possibility to upgrade whenever you choose.

Tailored for your surgical needs

Thanks to the different optic carriers available for the Leica M530, you can customize your surgical microscope to best fit your requirements whether neurosurgery, spine procedures, ENT, or plastic and reconstructive surgery.

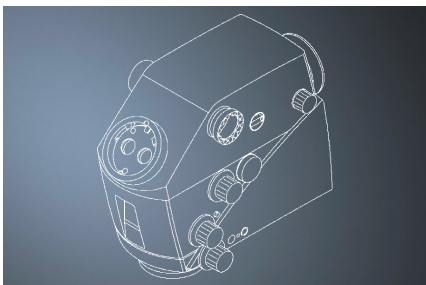

Ultraobserver

The Leica ULT530 is the standard configuration for neurosurgery, spine and plastic reconstructive surgery. Left, right and rear assistant interfaces and optional integrated Leica HD C100 camera, Leica FL800, Leica FL400 and Leica FL560 fluorescence modules offer maximum flexibility.

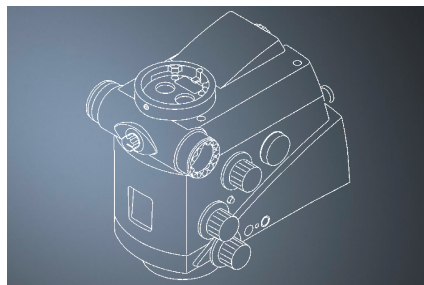

Integrated video adapter

The compact design of the Leica IVA530 offers an ideal solution for otolaryngology and neurotology. With no opposite assistant, more light is directed to the main surgeon and side assistant for even greater visual enhancement. The integrated video adapter has a built-in depth enhancer, for outstanding screen display and recording.

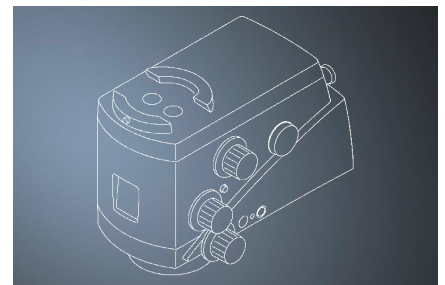

Image injection

The top plate configuration is designed for attachment of the Leica DI C500 dual imaging color module. The Leica DI C500 allows the surgeon to inject data directly into the eyepiece, from external and internal sources, such as MRI, CT, IGS, endoscopes and Leica FL800 video sequences.



Three-dimensional view for all

Integrated TrueVision 3D visualization and recording is also available. 3D imagery can greatly enhance microsurgery education, providing staff and students with the same 3D view as the surgeon during live surgery or a seminar. With TrueVision Smart 3D built in, set-up time is minimized and OR space freed up. 3D functions are controlled directly via the handles, avoiding workflow interruptions.



Fully integrated and under control

All cameras, fluorescence modules and cables are fully integrated inside the optics carrier to provide a sleek, clean appearance, maintain cable integrity and deliver greater freedom of movement. Control the HD 2D and 3D image recording functions or switch between white light and fluorescence via the handgrip or optional mouth and foot switches.



Ready for today and tomorrow

The modular, OpenArchitecture design of the optics carrier allows easy integration of systems such as the user-friendly Med X Change HDMD full HD digital recording system or Image Guided Surgery (IGS). Upgrade easily when your requirements change or when new imaging techniques or surgical guidance applications become available.



BEYOND THE VISIBLE

Well-prepared for current and future types of **surgical fluorescence** - the Leica M530 OH6 with TriFluoro*.

The Leica M530 OH6 can be supplied with three types of fluorescence fully integrated: Leica FL400 blue light fluorescence, Leica FL800 for vascular fluorescence and Leica FL560 green light fluorescence filter. With only a few button clicks, you can easily switch from white light to fluorescence mode or between fluorescence filters. The brilliant HD fluorescence video can be easily viewed on screen and recorded. For best viewing results, the built-in Mode Control video technology automatically optimizes the settings of specific, optional cameras according to the selected mode.

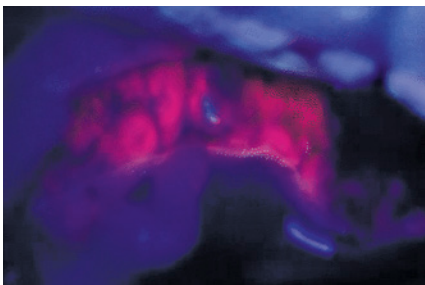

Glioblastoma tumor viewed with Leica FL400 and 5-ALA

FL400 oncological fluorescence

The fluorescence module Leica FL400 for M530 is used in conjunction with 5-ALA fluorescent agent for characterization of tumor tissue in open neurosurgery.

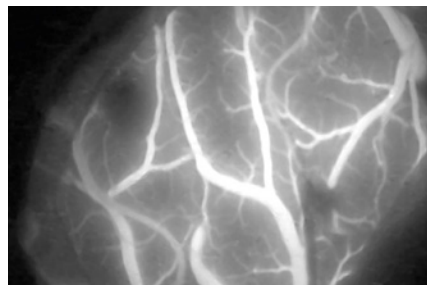

Neurovascular structure viewed with Leica FL800 and ICG

FL800 vascular fluorescence

The Leica FL800 ULT intraoperative videoangiography module is used in conjunction with ICG fluorescent agent and allows surgeons to see blood flow through vessels in real-time during surgery.

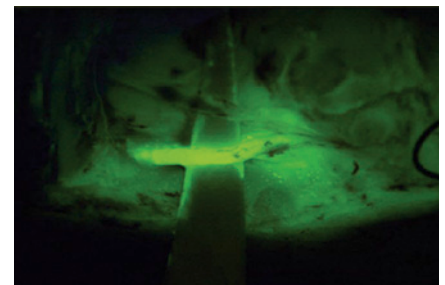

Lymphatic drainage pathway viewed with Leica FL560

FL560 fluorescence

The Leica FL560 for M530 module is designed to enable fluorescence observation of fluorophores with an excitation peak between ~460 nm and ~500 nm (blue) and fluorescence emission observation comprising the green, yellow, and red spectrum in a spectral band above ~510 nm.



STAY FOCUSED ON PATIENT SAFETY

The Leica M530 OH6 offers innovative design features, system back-up solutions, and illumination options to help you optimize patient safety and minimize interruptions.

Luxmeter for consistent lighting

BrightCare Plus compensates for decreased light intensity as bulbs age to ensure consistent lighting. With the internal luxmeter providing real-time light intensity data to the BrightCare Plus system, light intensity is calculated on actual bulb output, not by using an algorithm or formula.

Protection for team and patients

The Leica M530 OH6 features a special AgProtect coating for superior hygienic conditions. This surface coating with anti-microbial nano silver minimizes pathogens on the microscope as well as possible transmission to team members using it.

Made to withstand

The microscope's solid, full metal construction is highly robust. Designed and built for intensive use in the operating room, all the while maintaining its high level of precision and value.

OPTIMAL LIGHT INTENSITY

BrightCare Plus optimizes the light intensity relative to the working distance.

Max. illumination

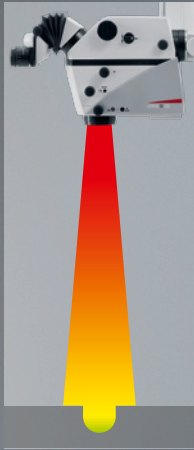

Long working distance.

Max. illumination
(BrightCare Plus inactive)

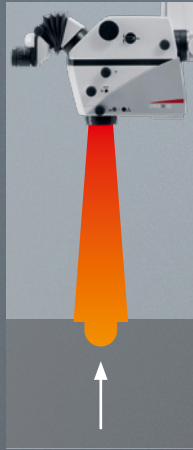

Decreased working distance at same illumination setting (left) creates burn potential in conventional microscopes.

Microscope with
BrightCare Plus activated

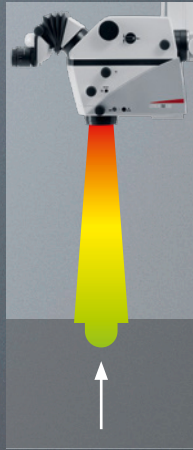

BrightCare Plus automatically adapts light intensity to the working distance, providing safer illumination (up to 60% reduction of light intensity).

OPTIMAL FIELD OF ILLUMINATION

Autolris automatically adjusts the diaphragm so that only the visible area is illuminated.

Conventional microscope
at low magnification

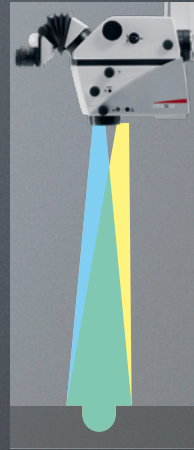

At low magnification, the field of illumination (yellow) fills the field of view (green) completely.

Conventional microscope
at high magnification

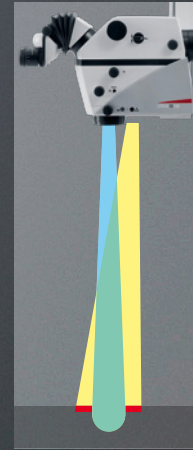

Previously, as magnification increased, the field of view became smaller, but the illumination outside the field of view could potentially cause tissue burns (red).

Leica Microscope
with Autolris

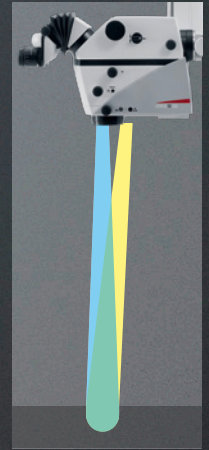

Autolris automatically works with the zoom, decreasing the field of view as the field of view decreases. There is no peripheral illumination to cause tissue burns outside the field of view.



Safe, maximum brightness

Maximum brightness at all times

The efficient light transmission of the Leica M530 OH6 ensures that the maximum possible amount of light is always being provided. Therefore, you can operate at safer light levels and still see more than ever before.



Bright 400-Watt Xenon light

Reliable illumination system

The Leica M530 OH6 features two redundant 400 W xenon arc-lamp illumination systems, with independent lamps and boards. In case of lamp or board failure, the microscope automatically switches to the second illumination system.



Separate operating systems for video and microscope

Stay operational

To ensure full operability the microscope and the video have fully independent operating systems. In case of a video system failure, the microscope retains full functionality and surgery can continue uninterrupted.

TECHNICAL SPECIFICATIONS

OPTICS AND ILLUMINATION

FusionOptics	For increased depth of field and high resolution for main surgeon
Fully apochromatic optics	For high contrast, natural colors without chromatic aberrations
Magnification	6:1 zoom, motorized
Total magnification	1.0× to 12.1× with 10× eyepiece
Magnification multiplier	1.4×(optional)
Focus	Motorized via multifocal lens, with manual adjustment
Fine focus	±5 diopter available for opposite assistant (ULT)
Objective / working distance	225–600 mm, motorized multifocal lens, continuously adjustable and manual adjustment option
Field of view	17.4 to 210 mm ø with 10× eyepiece
Eyepieces	Wide-field eyepieces for persons wearing glasses 8.3×, 10× and 12.5× dioptic adjustment, ±5 diopter settings and adjustable eyecup
Integrated 360° rotatable adapter	For main surgeon binocular (IVA, ULT) and opposite assistant (ULT)
Illumination	<ul style="list-style-type: none"> - High-output 2x 400-W redundant xenon arc-lamp systems via fiber optics cable - Continuously variable illumination field diameter with Gaussian distribution - Continuously adjustable brightness at constant color temperature
SpeedSpot	Laser focusing aid for fast and exact positioning of the microscope

MANEUVERABILITY

Optics	<ul style="list-style-type: none"> - 540° rotation - 50° lateral tilt to left and right - -30° /+120° inclination tilt
XY speed	Zoom linked XY speed
Balancing	One button/two push complete automatic balancing of stand and optics
Intraoperative balancing	Automatic intraoperative AC/BC balancing of AC and BC axes
Brakes	Floor stand with 6 electromagnetic brakes
Microscope carrier	“Advanced Movement” system with vibration damping technology
Carrier for monitor	700 mm flexible arm with 4 axis for rotation and inclination

MODULARITY

Leica ULT530	<ul style="list-style-type: none"> - Full stereo view for main surgeon and opposite assistant, semi stereo view for 2 side assistants - High sensitivity, built-in IR video camera with 1/2" CCD - Optional integrated HD Camera (Leica HD C100) - Light distribution: 50% for main surgeon, either 20% for each side assistant or 40% for opposite assistant
Leica FL800 ULT	ULT with the Leica FL800 vascular fluorescence observation filter module
Leica FL400	Leica FL400 blue light fluorescence observation filter module
Leica FL560	Leica FL560 green light fluorescence observation filter module
IVA530	<ul style="list-style-type: none"> - Full stereo view for main surgeon, semi stereo view for 2 side assistants and C-mount interface for camera (HD or SD) - Light distribution: 67% for surgeon, 23% for side assistant, 20% for C-mount port
Top plate with Leica DI C500	<ul style="list-style-type: none"> - Full stereo view for main surgeon and opposite assistant, semi stereo view for up to 2 side assistants - Data injection - Optional: C-mount interface for camera (HD or SD), FL800 function, FL400 function
OpenArchitecture	<ul style="list-style-type: none"> - Easy integration of IGS and laser systems (please ask your Leica Microsystems representative) - Prepared for integration of video camera system and digital recording system
Connectors	<ul style="list-style-type: none"> - Numerous built-in connectors for video, IGS and control data transfer - Internal power supply 12 VDC, 19 VDC and AC terminals
2D/3D HD Video	Fully integrated 2D HD and/or 3D HD video and recording

CONTROL

Control unit	<ul style="list-style-type: none"> - Programmable touch-screen with user-friendly Graphical User Interface for control of microscope and stand - ISUS Intelligent Setup System - Built-in electronic auto-diagnosis and user support - Software independent hard keys for illumination and auto-balancing - Indicator for main/backup illumination and fluorescence modes
Control elements	<ul style="list-style-type: none"> - Pistol handle with 10 programmable functions - Optional mouthswitch - Optional 12-function wireless footswitch
IR sensor	Leica FL400 oncological fluorescence observation filter module

SAFETY

Autolris	Built-in automatic zoom-synchronized illumination field diameter, with manual override and reset feature
BrightCare Plus	Safety function through working distance-dependent limitation of the brightness, controlled by a built-in luxometer

CONSTRUCTION

Base	720 × 720 mm with four 360° rotating castors with a diameter of 130 mm each, one parking brake
Materials	All solid metal construction coated with antimicrobial paint
Load	Min. 6.7 kg, max. 12.2 kg from microscope dovetail ring interface
Weight	Approx. 320 kg without load
Indicator	LEDs for fluorescence mode status and video record status

TECHNICAL DATA

Ambient conditions in use	<ul style="list-style-type: none"> - +10 °C to +40 °C - +50 °F to +104 °F - 30% to 95% rel. humidity - 800 mbar to 1060 mbar atmospheric pressure
Power connection	<ul style="list-style-type: none"> - 1600 VA 50/60 Hz - 100 V, 120 V, 220 V, 240 V (+10 %/–15 %) - 2 × T10 AL 100/120 V - 2 × T8 AL 220/240 V
Protection class	Class 1

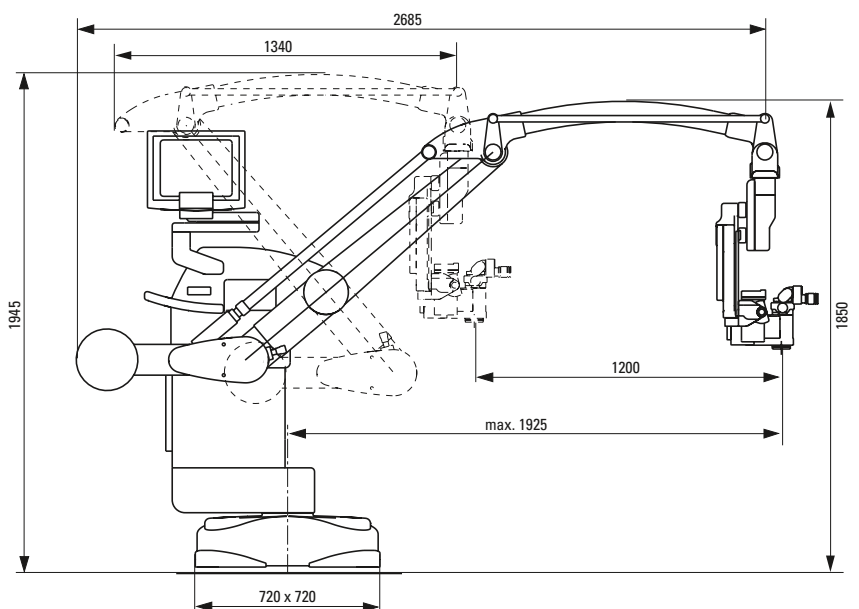
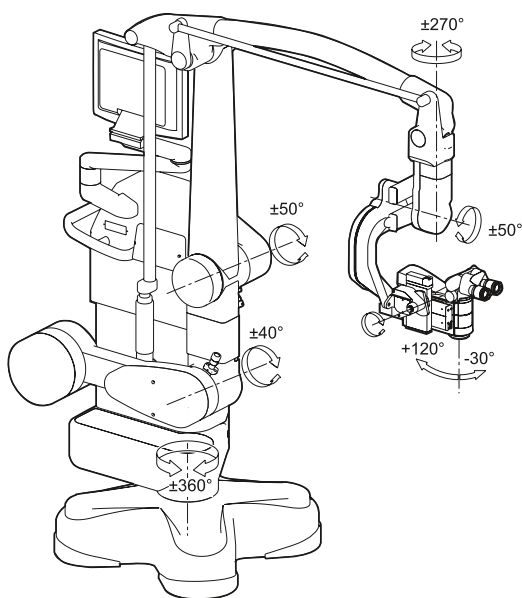



Leica Microsystems (Schweiz) AG
Max Schmidheiny-Strasse 201
9435 Heerbrugg, Switzerland



Class I surgical microscope Leica M530 OH6 incl. accessories

Class IIa FL800 ULT

Not all products or services are approved or offered in every market and approved labeling and instructions may vary between countries.
Please contact your local Leica representative for details.

Leica Microsystems (Schweiz) AG · Max Schmidheiny Strasse 201 · CH-9435 Heerbrugg

T +41 71 726 3333 · F +41 71 726 3399

www.leica-microsystems.com

CONNECT
WITH US!

