

From Eye to Insight



M525 OH4

Surgical Microscope Solution for
Precision Neurosurgery





OH4 stand designed by Mitaka



M525 OH4

Leica Microsystems stands for excellence in optics. Outstanding contrast, brilliance, sharpness, resolution, color fidelity, and precision are hallmarks of surgical microscopes. The OH4 stand, designed by Mitaka, not only complements the M525 optics, but also improves the overall microsurgical experience with superior movement, innovative illumination, and user-friendly features.

Designed and manufactured using superior materials and the highest quality standards, the premium M525 OH4 microscope is built for long service life and outstanding reliability.

OPTICAL EXCELLENCE

By integrating new glass, coatings, and design parameters, Leica's OptiChrome technology delivers the extra working distance, depth of focus, and light intensity needed for precision microsurgery. It forms the basis for the premium optical system. M525 optics deliver the following outstanding benefits compared to previous systems:

- **Longer** 32% extended working distance to 470 mm
- **Deeper** 30% increased depth of focus at same magnification
- **Brighter** 30% more light intensity
- **Sharper** Higher contrast and crisper, sharper images
- **Smarter** Autolris magnification-controlled illumination



ADVANCED ILLUMINATION

Illumination Settings: BrightCare

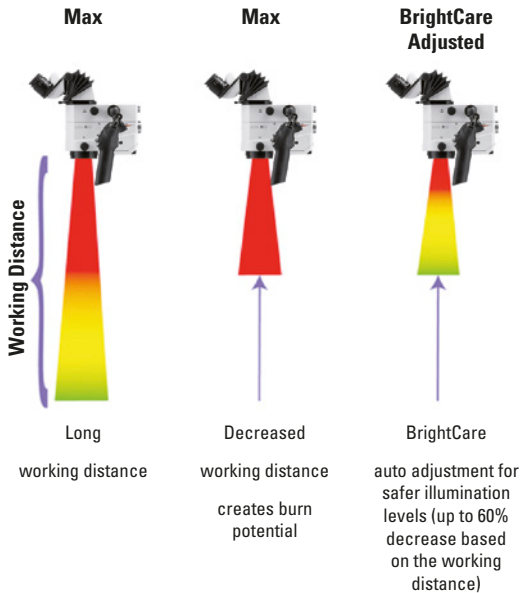

Illumination in an instant, always

The M525 OH4 microscope features two completely independent 300W xenon arc-lamp illumination systems, plus optional 400-watt illumination. The second system automatically activates in the event of lamp failure in the primary system, which gives the surgeon confidence to know that surgery will not be jeopardized due to lamp failure.

BrightCare – Working-distance-controlled illumination

As a microscope's working distance decreases, the intensity of the microscope light (without adjustments) increases. This can pose a risk of tissue burns to patients. Leica Microsystems' BrightCare working-distance-controlled light intensity feature addresses this issue to provide more safety for the patient by adjusting light intensity based on the working distance.

Illumination Settings: Autolris

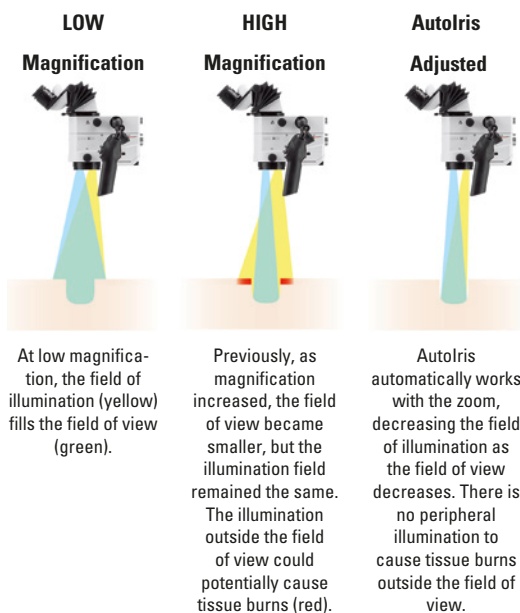

Autolris – Magnification-controlled illumination

As magnification increases, the field of view becomes smaller, but the illumination field remains the same. This can potentially cause tissue burns. To provide additional safety for the patient, Leica Microsystems' Autolris magnification-controlled illumination diameter automatically works with the zoom, providing a field of illumination that is only as wide as the surgeon's field of view.

SUPERIOR REACH AND HEIGHT

Compact, yet provides superior reach and ample overhead room

The M525 OH4 microscope features high overhead clearance and superior reach, providing the surgeon with ultimate flexibility to place the microscope wherever is most beneficial for the surgery.



COMPACT DESIGN



SUPERIOR OVERHEAD REACH

OH4 stand designed by Mitaka

The Leica M525 OH4 allows perfect positioning for surgery and takes up very little space in the operating room. The M525 OH4 provides superior reach, height, and clearance, which allows it to be conveniently located behind the surgeon in the unique overhead position, or positioned anywhere around or across the operating table.



LONG REACH

WIDE RANGE OF MOVEMENT



With its 100° range of lateral movement the surgeon can easily achieve the most challenging side views.

Extraordinary movement

The M525 OH4 microscope offers a wide range of movement in all dimensions for improved maneuverability. The microscope can be moved with very little force, and has minimal vibration at all magnification levels. The stand's patented advanced movement system achieves perfect balance in six axes and at all locations and angles of the microscope.

100° range of lateral movement provides the most difficult-to-manuever side views.

150° inclination angle range combined with the most compact microscope provides unmatched comfort, even in difficult positions.

Movement precision – The M525 OH4 microscope has robotic functions on two axes (X/Y) to allow a higher degree of precision movement.



The 150° range of inclination angle combined with a compact microscope provides unmatched ergonomics even in the most difficult positions.



The ergonomically designed mouth switch allows the surgeon to easily position the microscope, hands-free.



The ultra precise pistol grip provides control of the microscope, stand, and IGS and fluorescence functions.



FAST AND PRECISE BALANCE

True auto-balance

Leica Microsystems' single button auto balance feature saves valuable time. The surgeon activates this feature by simply pushing the auto-balance button, which fully balances all six axes for precise positioning.

Intraoperative re-balance

A microscope frequently needs re-balancing during surgery due to the surgeon's and assistant's need to change positioning. It is easy to re-balance the microscope intraoperatively, even through a sterile drape. Simply push the AC/BC button, conveniently located above the optical head, to quickly and accurately re-balance the microscope in seconds.

Taking control

Fast, precise control over all of the stand's functions, the microscope, and the accessories is vital in the operating room. The M525 OH4 microscope features a touch screen with intuitive graphical user interface.

Leica Microsystems' graphical user interface allows users to conveniently and intuitively control all microscope functions during surgery. Additionally, there are hard keys for illumination control and auto-balancing for added safety.



Intraoperative re-balancing for uninterrupted surgery.

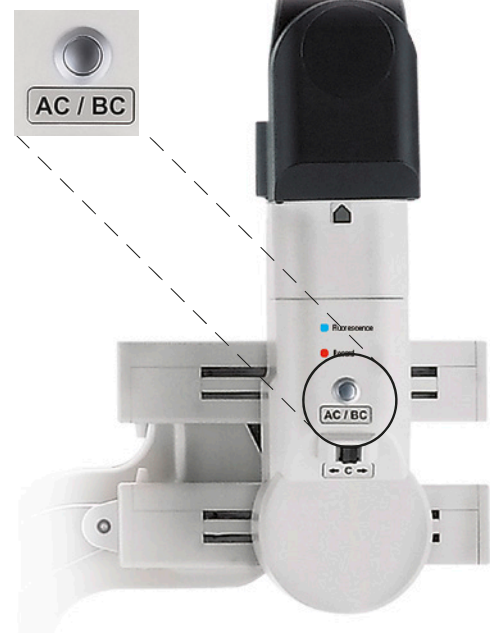

MOTORIZED INCLINATION AND TILT



The handle's ultra precise joystick allows micrometric movements for tilt and inclination. When preselected, it can also, for example, control the image injection functions.

The M525 OH4 has robotic functions on two axes (X/Y) to further enhance movement precision. The robotic functions can be activated by hand and/or foot controls.

Combined with an IGS computer, the stand's robotic ability allows the microscope to follow the surgeon's hand instruments, thus eliminating the need for the surgeon to take his/her hand away from the surgical site to move the microscope.

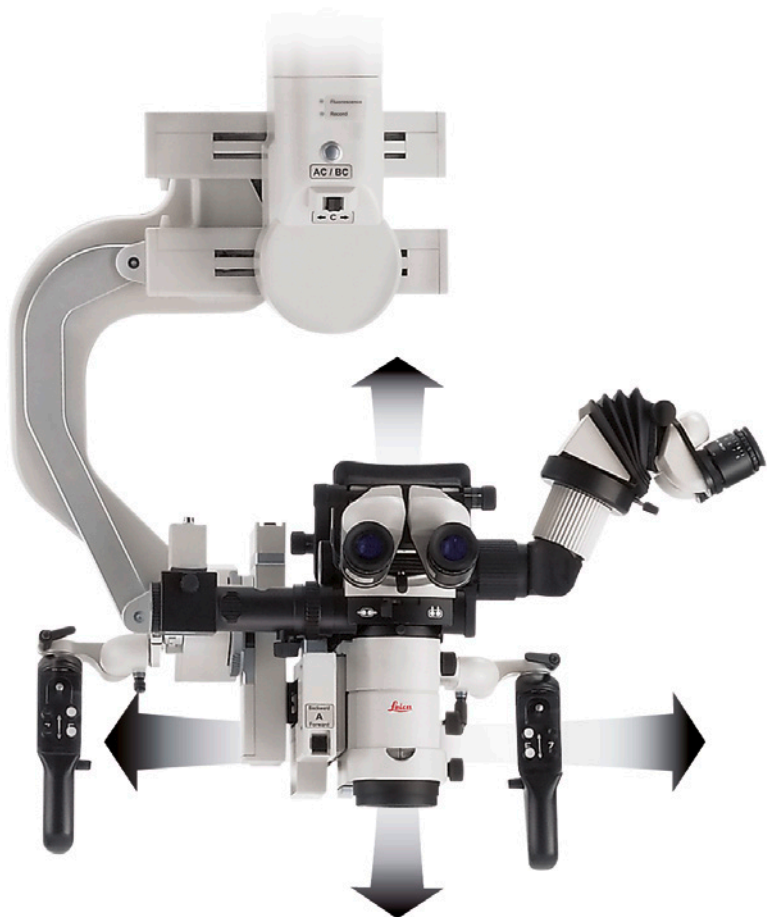

Combined with an IGS computer, the Leica OH4 stand's robotic ability allows the microscope to follow the surgical instruments.

INTEGRATED DIGITAL VIDEO

Video screen integrated with floor stand

The M525 OH4 microscope features a built-in, movable video screen arm, with three rotation axes and an inclination axis to best position the large video flat screen (optional) into the perfect position for all viewers. Also, all functions of the integrated video recording system are conveniently and directly controlled via the large video screen (using a keyboard, touch pad or touch screen option).



Full image coverage on a 24" HD flat screen and wireless video transfer to the surgeon's Apple® device (optional).

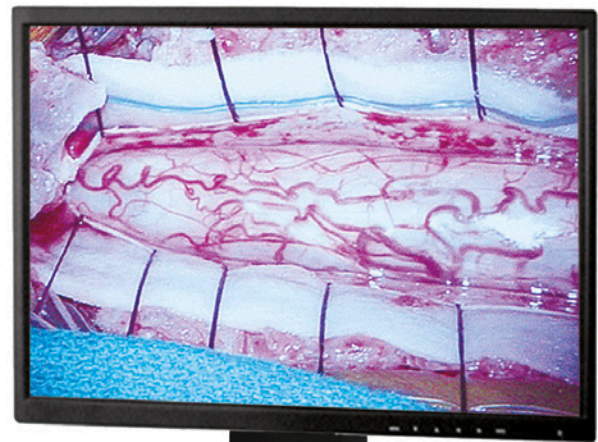

Wireless transfer of high-quality HD videos and still images of surgical cases to Apple® mobile devices

Med X Mobile, available at the Apple® App Store, allows a surgeon to wirelessly transfer surgical videos and stills directly from the Med X Change HDMD™ recording unit to the surgeon's Apple® iPhone, iPod Touch or iPad immediately upon procedure completion. This technology offers surgeons and staff yet another method to transport, view, and share stunning, high-quality content.



Ready for future imaging technologies

The selection of video options continually changes as imaging technology evolves. The M525 OH4 is an open architecture system that allows the surgeon to upgrade components as new video innovations become available. The Med X Change HDMD® high-definition digital recording system is easily integrated with the Leica M525 OH4 floor stand for convenience and easy accessibility.

Wide choice of Leica Video Adapters

All Leica video adapters offer an intra operative fine focus to adjust the video focus. This enables the surgeon to always achieve crisp and clear focus quality in documentation. For a smooth surgical workflow, the surgeon can also choose between manual or remote control. The remote control can be used sterile (with a sterile cover) or unsterile by any person in the OR. Finally, the c-mount interface allows the connection of a 1/2", 1/3", and HD camera.

The **Leica Zoom Video Adapter** (top left) allows focus and magnification adjustments independently of the surgeon's view.

The **Leica Dual Video Adapter** (top right) for vascular fluorescence cases is NIR optimized with fine focus and remote control.

The **Manual and Remote Video Adapters** (bottom left and right) both have a fine focus. Also, the remote control allows the Remote Video Adapter to be operated from any position and in any situation in the OR.



OPEN ARCHITECTURE

In combination with the tool tracking capabilities of an IGS system the optical axis and focal plane of the microscope follows the tip of a navigated tool in any lateral direction.

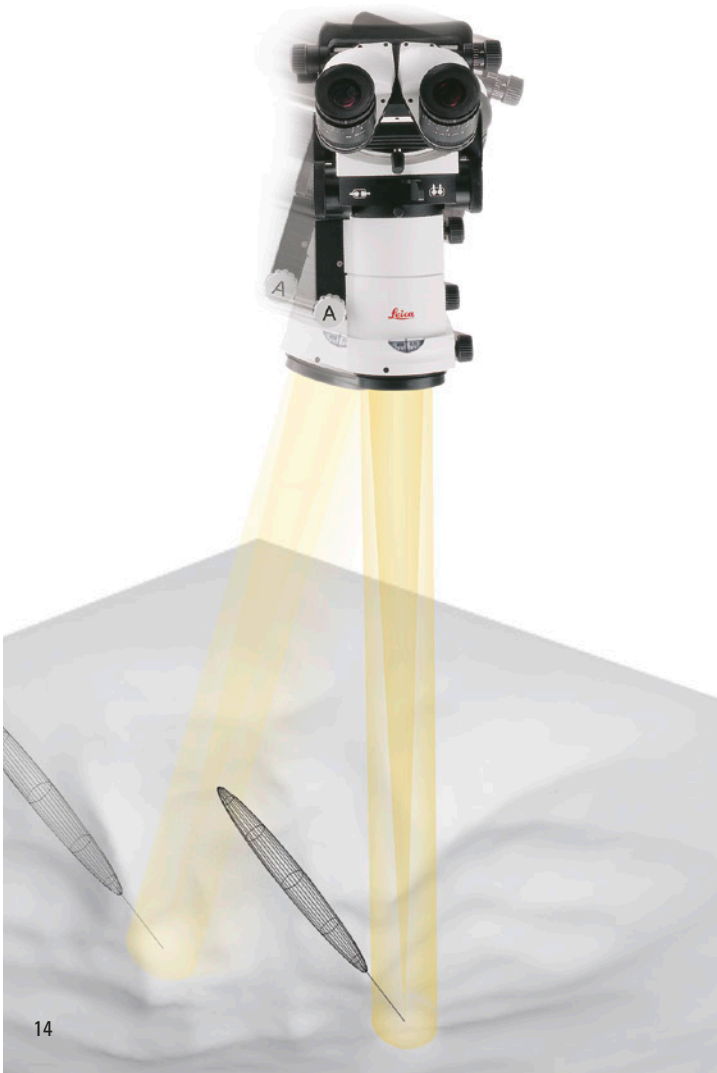

OpenArchitecture for IGS integration

The DI C500 dual imaging module allows the surgeon to inject data into the eyepieces from a variety of external sources such as MRI, CT, IGS, and endoscopes. With an IGS computer the CT or MRI can be fully correlated to the image in either eyepiece. The fully correlated image can be laid over the actual image or a shutter can be used, which displays the actual image in one eyepiece and the fully correlated image in the other eyepiece.



The DI C500 dual imaging module handles more data formats than ever before.

Neuro-endoscopy images

Non-correlated images, such as endoscope images, can be projected with high resolution and contrast. With the DI C500, the surgeon can view the endoscopy image in whichever microscope eyepiece he or she chooses.

Tool tracking

In combination with the tool tracking capabilities of an IGS system, the M525 OH4 microscope can track an instrument in the X,Y, and focus axis. Move the instrument and the microscope follows without the surgeon touching the handle grips.

INTRAOPERATIVE FLUORESCENCE

Intraoperative fluorescence

The study of fluorescence microscopy has a long tradition at Leica Microsystems. An indispensable component of biological research, fluorescence science is integrated with the technology of the surgical microscope to provide state-of-the-art fluorescence imaging

FL400

FL400 oncological fluorescence is used in conjunction with 5-ALA for visual differentiation of tumor tissue from normal brain tissue.

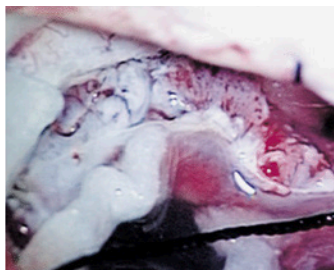

White light mode

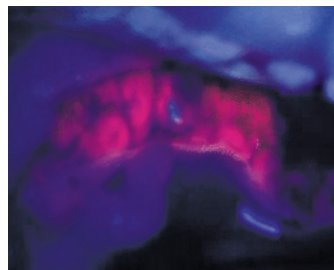

Blue light mode

FL800

FL800 fluorescence allows surgeons to view blood flow intraoperatively using Indocyanine Green (ICG)

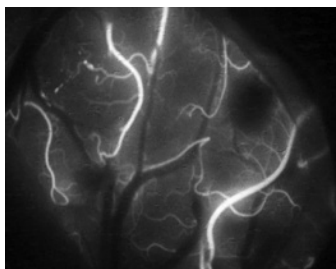

ICG injection after 2 seconds:
Arterial view

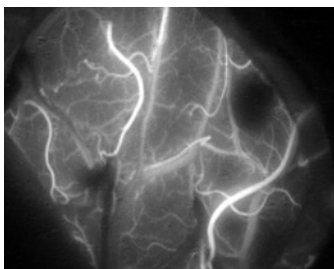

ICG injection after 5 seconds:
Capillary view

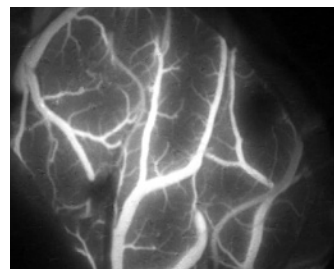

ICG injection after 9 seconds:
Venous view

SUPERIOR RELIABILITY AND SAFETY

Trusted reliability

Leica Microsystems utilizes superior materials and design technologies, and manufactures to the highest quality standards for long service life and outstanding reliability. The M525 OH4 microscope's full metal construction is designed to withstand intensive use in the operating room, remain precise throughout its life, and maintain its value. Smart engineering and special vibration-dissipating materials further support the stable, extra long swing arm. The OH series has proven to be consistently reliable.

Full metal construction

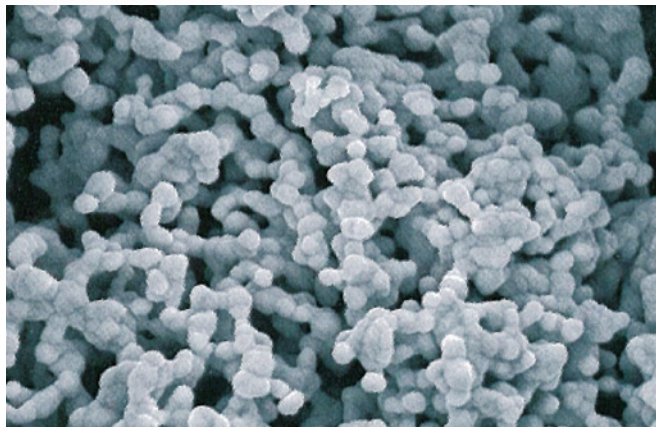

Typical structure of a metal powder (Ag) produced via inert gas condensation (nano powder).

AgProtect: anti-microbial coating for added safety

Leica Microsystems' antimicrobial nano silver coating, AgProtect, provides outstanding protection to microscope users by reducing exposure to surface pathogens. AgProtect covers the microscope's outside surface and protects the operator and other individuals in the work area by penetrating the membranes of microbes to prevent replication. Leica Microsystems develops instruments with added safety for its customers, medical teams, and their patients through AgProtect.

TECHNICAL SPECIFICATIONS

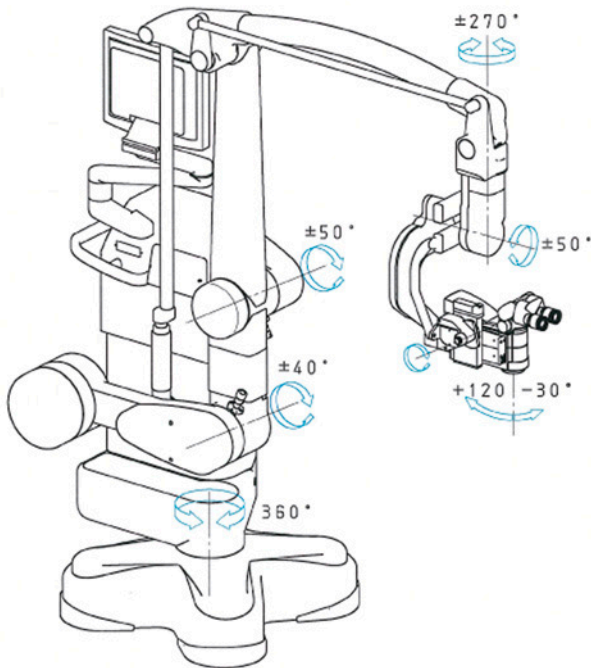
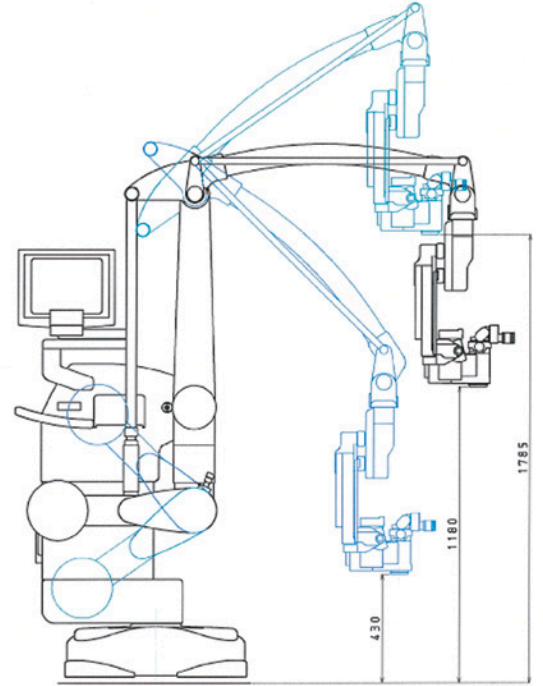
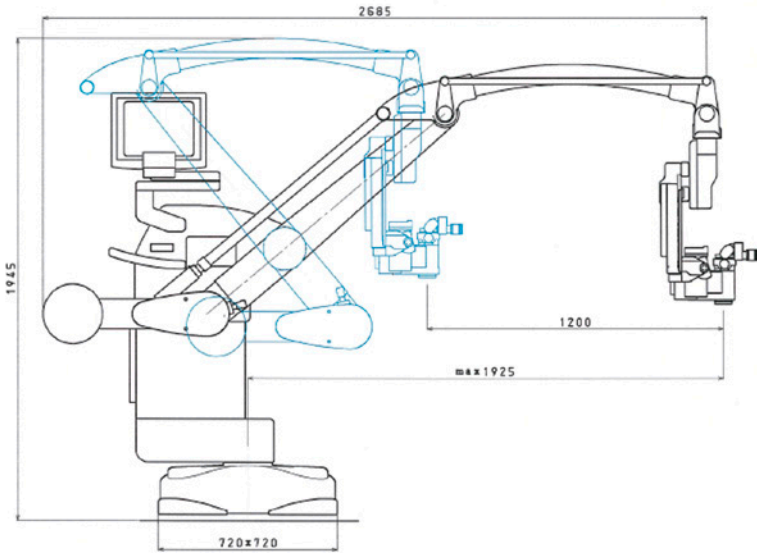

Dimensions in mm

ELECTRICAL DATA

Power connection	1600 VA 50/60 Hz 100 V (+10%/-15%), 120 V (+10%/-15%), 220 V (+10%/-15%), 240 V (+10%/-15%)
Safety class	Class 1

M525 MICROSCOPE

Magnification	6:1 zoom, motorized
Focus	Motorized via multifocal lens, with manual adjustment
Eyepieces	Widefield eyepieces for eyeglass wearers 10× and 12.5×, dioptric setting ±5 with adjustable eye cup
Objective	Multifocal lens, 207 mm to 470 mm variable working distance through motorized lens, continuously adjustable, with manual override Optional WD extender lens (not for IGS applications)
Illumination	Continuously adjustable illumination field diameter with Gauss-shaped light distribution; continuously adjustable brightness at a constant color temperature
Main light source	High-performance 300 Watt xenon arc-lamp through fiber optic
Emergency lamp	300-Watt xenon arc-lamp on a separate electrical system and optional 400-Watt xenon illumination
Autolris	Built-in, automatic, zoom-synchronized illumination field diameter, with manual override and reset feature
BrightCare	Safety technology for the working distance-synchronized light control

OPTICAL DATA

Magnification range	1.2× – 12.8× with 10× eyepiece
Field of view	16.5 mm to 180 mm with 10× eyepiece

MICROSCOPE CARRIER

Rotation of optics	540°
Lateral tilt	50° to left / 50° to right
Inclination tilt	-30° / +120°
XY speed	Zoom-correlated XY speed
Balancing	A, B, C, and D axes are fully automatic, each can be manually balanced
Intraoperative balancing	AC/BC button for automatic intraoperative re-balancing of the A and C axes, and for re-balancing the B and C axes
Brakes	1 brake for A/B axis, 1 brake for C axis
Indicator	LED for fluorescence mode status, LED for video record status

ACCESSORIES

Leica ULT500	180° stereo observer ports with selectable lateral or opposite assistant: Main surgeon and opposite assistant 40% each eyepiece, lateral assistant / video 20% each eyepiece / beam path
Second observer	Dual stereo attachment: 50% each eyepiece
Beam splitter	50% / 50%, 70% / 30%
Binocular tube	Variable angle 0° – 180° Variable angle 30° – 150°
Video adapter	Leica Manual Video Adapter (MVA), 55 mm, 70 mm, 107 mm focal length, c-mount, with fine focus Leica Remote Video Adapter (RVA), 55mm, 70 mm, 107 mm focal length, c-mount, with fine focus Leica Zoom Video Adapter (ZVA), 3:1 zoom, 35 mm to 100 mm focal length, c-mount, with fine focus Leica NIR Dual Video Adapter (DVA), 60.6 mm, 79.5 mm focal length, c-mount, with fine focus
Video and recording	HD video camera and recording (optional)
Imaging injection	Leica DI C500 high resolution true dual imaging color module for correlated and non correlated data display
Asepsis	Sterilizable protective glass for the objective; sterilizable components for all drive knobs, commercially available drapes

IGS

IGS interface / compatibility	Open architecture for IGS systems
-------------------------------	-----------------------------------

FLUORESCENCE*

FL800	Optional FL800 is available in the USA, EU, and most other countries
FL400	Optional FL400 is available in the EU, and some other countries

*Please check the status of regulatory approval with your local Leica Microsystems representative.

TECHNICAL SPECIFICATIONS

M525 OH4

OH4 FLOOR STAND

Type	Floor stand with six electromagnetic brakes
Base	720 mm × 720 mm with four 360° rotatable casters of 130 mm diameter each; one central, single step foot brake
Balancing	One button / two pushes for complete, automatic balancing of stand and optics
Intraoperative re-balancing	AC / BC button for automatic intraoperative re-balancing of the AC axis and the BC axis
Swing arm	Patented advanced movement system for perfect balance in six axes, vibration-dissipating technology
Floor stand control unit	New generation touch panel technology. The latest electronics control for continuous control of all motor functions and the light intensity. Data shown by means of LCD. Built-in BrightCare technology for working distance synchronized light control. ISUS Intelligent Setup System, menu selection based on unique software for user-specific configuration, with built-in electronic auto-diagnosis and user support. Software-independent hard keys for illumination and auto-balancing. Indicator for main / backup illumination and fluorescence modes. Open architecture for future software developments.
Light source	Dual xenon arc-lamp illumination system and built-in, quick lamp changer
Controls	10-function pistol grips for zoom, focus, all-free release of six brakes, side button for user-defined brakes, motorized lateral tilt and inclination (XY), DI C500 or fluorescence functions. Except for the all-free button, all functions are freely programmable. Mouth switch for releasing the user defined brakes 12-function foot control, hand switch
Integration of documentation	Prepared for integration of video- and digital recording systems. Open architecture
Connectors	Numerous built-in connectors for video, IGS, and control data transfer
Carrier for monitor	700 mm long Flexible arm with 4 axes for the rotation and inclination required to carry optional video monitor
Materials	All solid metal construction
Surface coating	Coated with antimicrobial paint (AgProtect)
Minimal height	In parked position 1945 mm
Range cantilever	Max. 1925 mm
Load	Min. 6.7 kg and max. 12.2 kg of accessories to the microscope
Weight	Approx. 320 kg without load

HD IMAGING

For more information, please refer to your local Leica Microsystems Sales Representative.

AMBIENT CONDITIONS

In use	+10° C to +40° C (+50° F to +104° F), 30% to 95% rel. humidity, 500 mbar to 1060 mbar atmospheric pressure
Storage	-40° C to +70° C (-40° F to +158° F), 10% to 100% rel. humidity, 500 mbar to 1060 mbar atmospheric pressure

LIMITATIONS OF USE

The Leica M525 OH4 surgical microscope may be used only in closed rooms and must be placed on a solid floor.



Leica Microsystems (Schweiz) AG
Max Schmidheiny-Strasse 201
9435 Heerbrugg, Switzerland



Class I surgical microscope M525 OH4 incl. accessories.
FL800 ULT and FL400.

Not all products or services are approved or offered in every market and approved labeling and instructions may vary between countries.
Please contact your local Leica representative for details.

Leica Microsystems (Schweiz) AG · Max Schmidheiny Strasse 201 · CH-9435 Heerbrugg
T +41 71 726 3333 · F +41 71 726 3399

www.leica-microsystems.com

CONNECT
WITH US!

